

(No Model.)

J. A. BECHER.
BOLT THREADING MACHINE.

No. 411,002.

Patented Sept. 17, 1889.

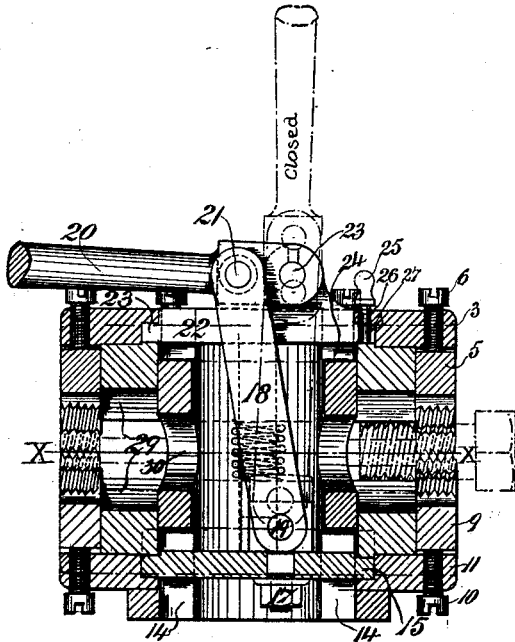

Fig 1

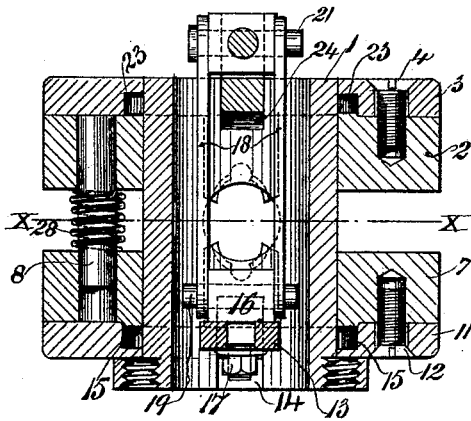

Fig 2

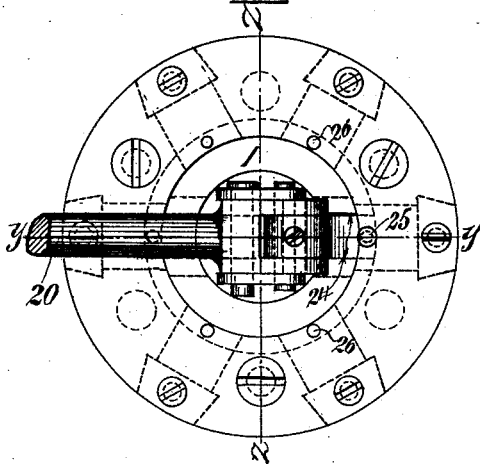

Fig 3

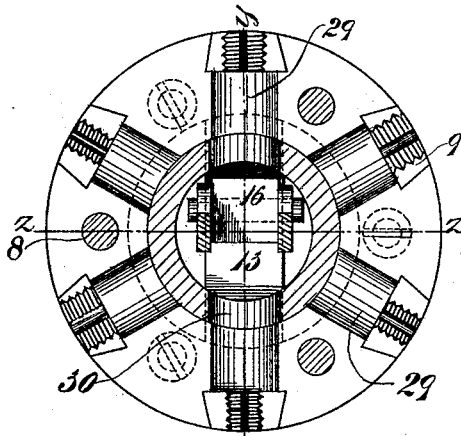

Fig 4

WITNESSES:

M. W. DeFries
Richd H Sullivan

INVENTOR

James A Becher

BY

J. R. Bell

ATTORNEY

UNITED STATES PATENT OFFICE.

JAMES A. BECHER, OF MISHAWAKA, INDIANA.

BOLT-THREADING MACHINE.

SPECIFICATION forming part of Letters Patent No. 411,002, dated September 17, 1889.

Application filed February 11, 1889. Serial No. 299,445. (No model.)

To all whom it may concern:

Be it known that I, JAMES A. BECHER, a citizen of the United States, residing at Mishawaka, county of St. Joseph, in the State of Indiana, have invented new and useful Improvements in Turret Bolt-Threading Machines, of which the following is a specification.

My invention relates to improvements in turret bolt-threading machines in which a stationary turret or die carrier, consisting of an upper and a lower opening and closing halves for jaws, is provided with thread-cutting dies or chasers arranged around its periphery.

The object of my invention is to provide means by which various sizes and pitches of screws can be cut rapidly and without reversing the machine, and, further, means for opening and closing the turret-jaws, hereinafter described. I attain these objects by the mechanism illustrated in the accompanying drawings, in which—

Figure 1 is a sectional elevation through *yy*. (See Figs. 3 and 4.) Fig. 2 is a sectional elevation through *ZZ*. (See Figs. 3 and 4.) Fig. 3 is a top view or plan of turrets, and Fig. 4 is a sectional plan of turret through the lines *xx*. (See Figs. 1 and 2.)

Similar numbers refer to similar parts throughout the several views.

1 designates the turret sleeve-post, (preferably of cast-iron,) secured by bolts or other suitable devices to the carriage of an ordinary lathe or screw-cutting machine.

2 designates the turret's upper opening and closing jaw, (also preferably of cast-iron.) 3 is its cap, secured thereto by the countersunk screws 4, and 5 are its dies, of variously predetermined sizes, (preferably of an even number,) arranged radially around its periphery and adjusted by their set-screws 6.

7 designates the opening and closing bottom turret-jaw, (also preferably of cast-iron,) arranged to slide on the sleeve-post, and receiving, sliding on, and held in position by the guide stop-pins 8, (preferably of steel,) secured to upper turret-jaw 2. 9 are its dies, corresponding with and directly opposite to the dies 5 of the upper turret-jaw 2, and are also arranged radially around its periphery

and adjusted by their set-screws 10, and adapted to co-operate with their corresponding and adjacent dies 5 in the upper turret-jaw 2, and 11 is its cap, secured by the countersunk screws 12.

The cross-piece 13, sliding up and down only in the slots 14, and having its reduced ends loosely inserted into the annular grooves 15, formed in the turret-jaw cap 11, the toggle-bolt 16, secured thereto by the nut 17, and the toggles 18, pivoted on their bottom ends to the bolt 16 by the pin 19 and on their top or upper ends to the operating-handle 20 by the pin 21, said operating-handle 20 being pivoted to the fulcrum 22 by the pin 31, said fulcrum 22 being also arranged to slide a limited distance in slot 24, constitute the opening and closing mechanism of my invention. The fulcrum 22 also has its reduced ends inserted into annular groove 23, and is held in its fixed diametrical position relative to the post 1 by the notches 24 formed thereon, and is free to move up and down therein a limited distance.

I provide the stop-pin 25, fitting the holes 26, formed in the turret-cap 3 at the same radial distance from its center as the hole 27, formed in end of fulcrum 22 and coinciding with the radial center line of each of the pairs of dies 5 and 9, for the purpose of maintaining the turret in a fixed position while using any one pair of the series of dies in threading a bolt of corresponding diameter. The reduced ends of the fulcrums 22 and 13, inserted into annular groove 23 and 15, hold the upper and lower jaws of the turret in their proper radial position, at the same time permitting the simultaneous rotation of the upper and lower turret-jaws 2 and 7 and their attachments.

The upper and lower turret-jaws 2 and 7 and their attachments are subject to a motion of translation along the turret-sleeve 1, which, in the operation of closing or advancing the jaws and their dies, is limited by the amount of end clearance of the guide-pin 8 from the plate 11, and in the reverse operation of opening or receding by the amount of eccentricity or throw of the hand-lever 20, the amount of throw being equally divided between both upper and lower jaws 2 and 7 and adjusted

by the clearance between the bottom jaw-plate 11 and collar of turret-post 1, the hand-lever being permitted to drop a portion of its swing till contact is obtained between the
 5 lower turret jaw-plate 11 and post-collar 1. The remaining portion of the throw is taken up by the springs 28, thus raising the upper jaw 2 and relieving or disengaging the dies 5 and 9 from the bolt operated upon.

10 The operation of my attachment is as follows: When it is desired to thread a bolt of a diameter corresponding with one of the pairs of the series of dies, the stop-pin 25 is removed and the turret is revolved till the pair
 15 of dies suited to the blank or rod to be threaded are in their working position opposite the bolt. The stop-pin is reinserted into the holes 26 and 27, thus maintaining the turret in position. The blank or rod is rotated
 20 at a suitable velocity by means of any convenient rotating head, by which it is held, the said head being secured to a lathe or screwing-machine spindle. The turret upper and lower jaws 2 and 7 are closed till the guide-pins contact with the cap 11 by means of the operating-
 25 handle 20 and its toggles 18, thus bringing the upper and lower dies 5 and 9 into their proper threading position, and consequently the same radial distance apart from the center of the bolt operated upon, in which position the entire turret-jaws 2 and 7 are suspended by the
 30 fulcrum 22, resting and held in position by the notches 24 on post 1, as shown by the dotted lines in Fig. 1. The carriage carrying the turret is moved or fed to and along the blank till a requisite length of its surface is threaded. The operating-handle 20 is dropped into its horizontal position, thus opening the dies and permitting the turret to be with-
 40 drawn without reversing the rotation or stopping the machine, and at the same time permitting a free exit of the cuttings through the radial channel or groove 29 on line with the cutting-dies.

45 It is obvious that, no matter what the size of the blank to be threaded, the operation can be performed without loss of time in stopping the machine by simply rotating the turret in the manner hereinbefore described and
 50 bringing the proper dies into operation.

I provide the grooves 29, formed on the inner surface of the upper and lower turret-jaws 2 and 7, and the opening 30, formed in the turret-post 1, for the purpose of permit-
 55 ting a long bolt to pass through and between the turret-jaws and post while being threaded.

It is obvious that an upper and a lower single cutting-tool, such as is used in the ordinary screw-cutting lathe, may be substituted
 60 for the threading-dies hereinbefore described without departing from the spirit of my invention. If such cutting-tools are used, the turret-carriage must be provided with a self-acting feed-screw or other suitable device,
 65 such as is used in the ordinary screw-cutting machine.

I am aware that previous to my invention

stationary turrets having various sizes of threading-dies arranged around their periph-
 70 eries have been used in connection with screw-cutting machines. I therefore do not claim such a combination, broadly; but

What I do claim as my invention, and desire to secure by Letters Patent, is—

1. In a screw-cutting turret-head, the com-
 75 bination of a turret-post with its upper and lower opening and closing turret-jaws, and their cutting-dies arranged around their peripheries, and mechanism for operating the said jaws, substantially as and for the pur-
 80 pose described.

2. In a screw-cutting turret-head, the combination of a turret-post with its upper and lower opening and closing turret-jaws and their corresponding pairs of dies adjustably
 85 secured around their peripheries, substantially as and for the purpose described.

3. In a screw-cutting turret-head, the combination of the receding and approaching turret-jaws mounted and moving freely on a
 90 suitable supporting-post, with their corresponding pairs of cutting-dies arranged around their peripheries and having their cutting-faces turned inwardly, substantially as and for the purpose described.

4. In a screw-cutting turret-head, the combination of an upper receding and approaching turret-jaw with a similar lower turret-jaw
 100 mounted and adapted to rotate on a suitable post, said upper and lower jaws having radial grooves formed on their inner surfaces coincident with the radial centers of the cutting-dies, substantially as and for the purpose described.

5. In a screw-cutting turret-head, the upper
 105 and the lower receding and approaching turret-jaws mounted and adapted to rotate on a suitable post, said jaws having radial grooves formed on their inner surfaces and arranged in opposite pairs to coincide with opening
 110 formed in turret-post in line of centers of cutting-faces of dies, substantially as and for the purpose described.

6. In a screw-cutting turret-head, the combination of an upper receding and approaching
 115 turret-jaw and its guide-pins secured perpendicularly to its inner surface, with a lower receding and approaching turret-jaw, the latter jaw being provided with guide-holes formed therein to loosely receive said guide-
 120 pins, substantially as and for the purpose described.

7. In a screw-cutting turret-head, the combination of an upper receding and approaching
 125 turret-jaw and its guide-pins secured perpendicularly to its inner surface with a similar lower turret-jaw provided with guide-holes to freely receive said guide-pins, said jaws arranged to be rotated simultaneously,
 130 substantially as and for the purpose described.

8. In a screw-cutting turret-head of the character described, the combination of an upper turret-jaw and its cap secured thereto
 and an upper cross-head arranged to slide in

guides formed in turret-post, and having its projecting ends inserted into an annular groove formed between the surfaces of the said upper turret-jaw and its cap, with a lower turret-jaw, cap, and cross-head of like construction, and toggle-links connecting said cross-heads for opening and closing said jaws, substantially as and for the purpose described.

9. In a screw-cutting turret-head, the combination of an upper receding and approaching turret-jaw and a lower receding and approaching turret-jaw with their expanding springs contacting with inner surfaces of said jaws, substantially as and for the purpose described.

10. In a screw-cutting turret-head, the combination, with the turret-post, the turret-jaws, and their cross-heads, of the character described, of an interchangeable stop-pin arranged to be inserted into stop-holes formed in top turret-cap and top cross-head, substantially as and for the purpose described.

11. In a screw-cutting turret-head of the character described, the combination, with the post 1, fulcrum 22, carrying turret-cap 3, and its upper disengaging jaw 2, having adjustable dies 5 arranged around its periphery and adjusted by the screws 6, of the lower disengaging turret-jaw 7 and its cap 11, said jaw 7 having adjustable dies 9 arranged around its periphery and adjusted by the screws 10, and means for opening and closing the jaws, substantially as and for the purpose set forth.

12. In a screw-cutting turret-head, the combination, with the upper disengaging turret-jaw 2 and its cap 3, mounted on post 1 and having the guide-pin 8 secured thereto, and their spring 26, encircling said pins, of the lower disengaging turret-jaw 7 and its cap 11, said jaw provided with holes to loosely receive said guide-pins and limited in its motion by its cap 11, connecting with end of said guide-pins, substantially as and for the purpose described.

13. In a screw-cutting turret-head, the combination of the turret-post and its upper and lower disengaging jaws with the cross-piece sliding in the slots 14 and having its ends inserted in the annular groove 15, the toggles 18, hinged to bolt 16 by the pin 19 on their lower ends and on their upper ends to the handle 20 by the pin 21, and handle fulcrumed by the pin 23 to the fulcrum 22, sliding in notches 24, formed on turret-post 1, and having its ends inserted in grooves 23, formed in cap 11, all substantially as and for the purpose described.

In testimony whereof I have hereunto set my hand in the presence of two subscribing witnesses.

JAMES A. BECHER.

Witnesses:

T. R. BELL,
A. C. BRAZINGTON.